

ASSEMBLY INSTRUCTIONS

PENN CURVED TABLE SET



PLEASE READ THESE STEPS BEFORE PROCEEDING

Included with your Penn Curved Table Set is the Following Hardware:

- Eight (8) 1/2" Stainless Steel Flat Washers
- Four (4) 1/2" Stainless Steel Hex Head Nuts
- Four (4) 1/2" Stainless Steel Lock Washers
- Four (4) 1/2" x 1 1/2" Stainless Steel Hex Head Cap Screws
- Forty-four (44) 3/8" Stainless Steel Flat Washers
- Twenty (20) 3/8" x 1 1/2" Stainless Steel Hex Head Cap Screws
- Four (4) 3/8" x 1" Stainless Steel Hex Head Cap Screws
- Twenty (20) 3/8" Stainless Steel Hex Head Nuts
- Twenty (20) 3/8" Stainless Steel Lock Washers

ABIDE BY THE FOLLOWING INSTALLATION INSTRUCTIONS

Braces

1. Place braces perpendicular to each other.
2. Pick up the brace with the center hub that is higher up the brace and put it on top of the other brace making sure that the holes in the hubs line up.
3. Place a 3/8" flat washer on a 3/8" x 1 1/2" cap screw and insert it through the holes in the hubs.
4. Place 3/8" flat washer over threaded end of cap screw, then add 3/8" lock washer and nut. Only hand tighten nuts and bolts on this step.

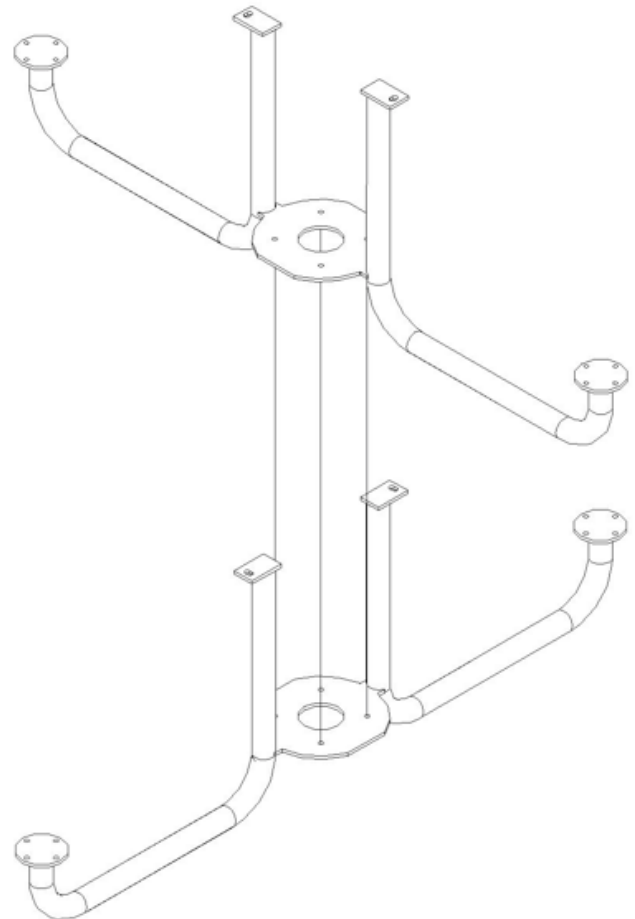

ASSEMBLY INSTRUCTIONS (con't)

PENN CURVED TABLE SET

Table

1. Place tabletop plate on pedestal, aligning the holes on the plate with the holes on the pedestal.
2. Add 1/2" flat washer to 1/2" x 1 1/2" cap screw and insert down through the holes in the plate.
3. Add 1/2" flat washer and 1/2" lock washer and nut to underside of cap screws just inserted.
4. Add table top on top of plate aligning holes in the plate with the coupling nuts welded to the support straps on the bottom on the table top.
5. Add 3/8" flat washer to 3/8" x 1" cap screw and insert down through the hole in the table and pedestal.
6. After tightening table top down, tighten table plate bolts and nuts. (Shown upside down for clarity)

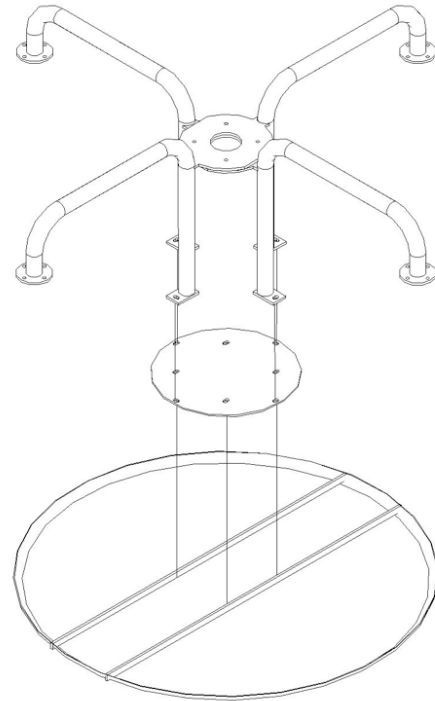

Seat

1. Place curved seat on top of seat pedestal, matching up holes on both pieces.
2. Add 3/8" flat washer to 3/8" x 1 1/2" cap screw and insert through holes in seat and pedestal.
3. Slide 3/8" flat washer over exposed threads and add 3/8" lock washer and nut and tighten.

