

# ASSEMBLY INSTRUCTIONS

## SCHENLEY TABLE SET



### PLEASE READ THESE STEPS BEFORE PROCEEDING

Included with your Schenley Table Set is the Following Hardware:

- Eight (8) 1/2" Stainless Steel Flat Washers
- Four (4) 1/2" Stainless Steel Lock Washers
- Four (4) 1/2" Stainless Steel Hex Nuts
- Four (4) 1/2" x 1 1/2" Stainless Steel Hex Head Cap Screws
- Forty-Four (44) 3/8" Stainless Steel Flat Washers
- Twenty (20) 3/8" x 1 1/2" Stainless Steel Hex Head Cap Screws
- Four (4) 3/8" x 1" Stainless Steel Hex Head Cap Screws
- Twenty (20) 3/8" Stainless Steel Hex Head Nuts
- Twenty (20) 3/8" Stainless Steel Lock Washers

### ABIDE BY THE FOLLOWING INSTALLATION INSTRUCTIONS

#### Braces

1. Place braces perpendicular to each other.
2. Pick up the brace with the center hub that is higher up the brace and put it on top of the other brace making sure that the holes in the hubs line up.
3. Place a 3/8" washer on a 3/8" x 1 1/2" cap screw and insert it through the holes in the hubs.
4. Place 3/8" flat and lock washer over threaded end of cap screw, then add 3/8" nut. Only hand tighten nuts and bolts on this step.

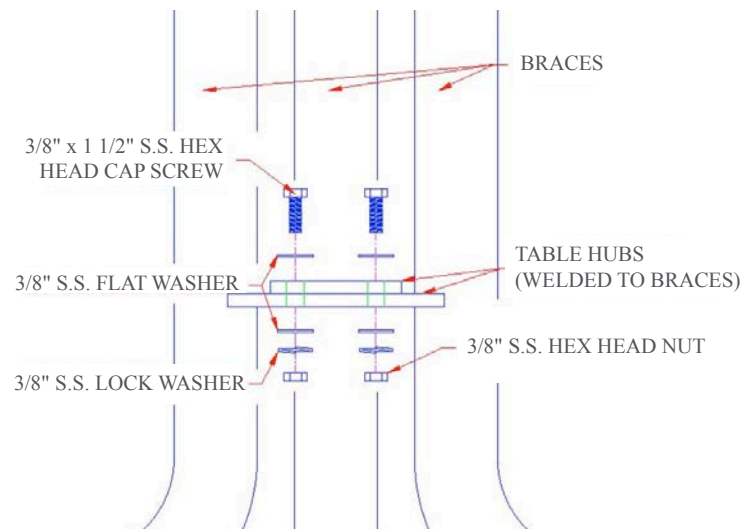
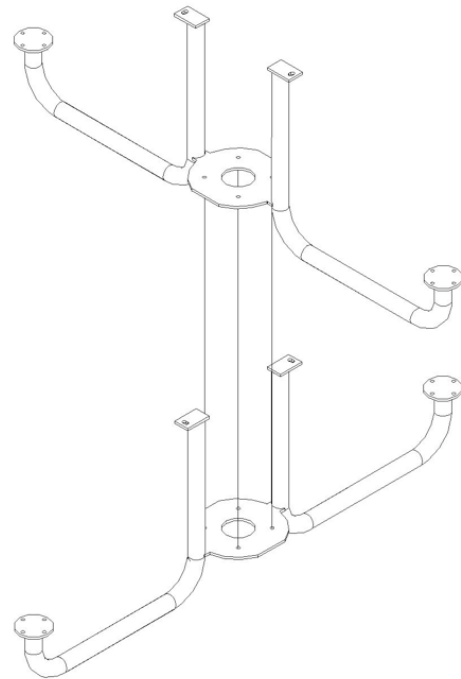

# ASSEMBLY INSTRUCTIONS (con't)

## SCHENLEY TABLE SET

### Legs to Table Plate

1. Place table plate on pedestal, aligning the holes on the table plate with the holes on the pedestal.
2. Add 1/2" washer to 1/2" x 1 1/2" cap screw and insert down through the hole in the table plate and pedestal/legs.
3. Slide 1/2" flat and lock washer over exposed threads and add 1/2" hex nut and tighten.
4. After tightening table plate down, tighten brace screws.

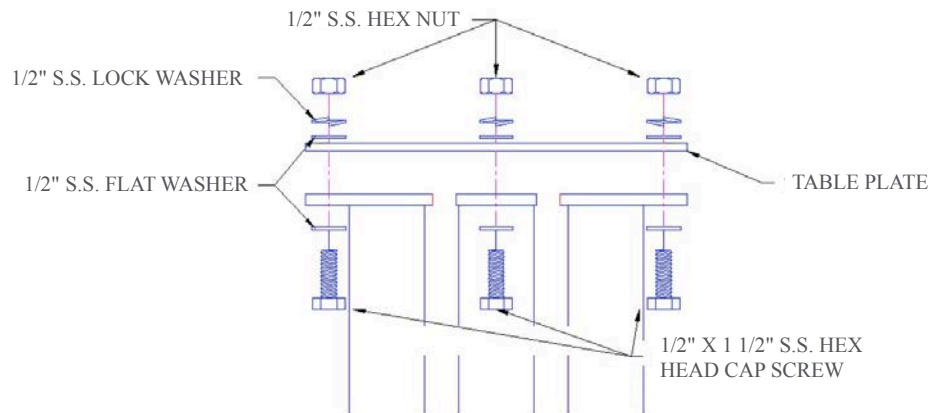

### Legs / Table Plate Assembly to Table Top

1. Place table top over leg/table plate assembly, making sure to align the holes in the table mounting plate with the coupling nuts under the table.
2. Place 3/8" flat washer over 3/8" x 1" hex head cap screw and insert up through holes in mounting plate and thread into coupling nuts.
3. Tighten hex head cap screws into coupling nuts under table.

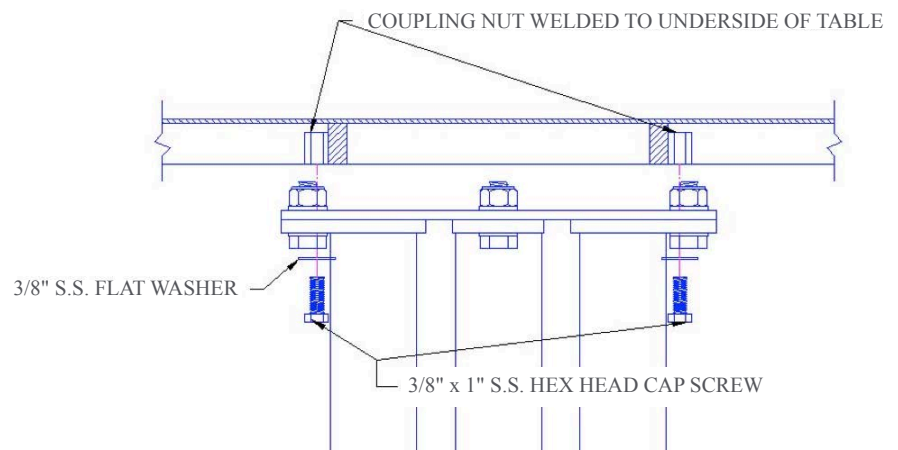

# ASSEMBLY INSTRUCTIONS (con't)

## SCHENLEY TABLE SET

### Seat

1. Place seat on top of pedestal, matching up holes.
2. Add 3/8" flat washer to 3/8" x 1 1/2" cap screw and insert through holes in seat and pedestal.
3. Slide 3/8" flat and lock washer over exposed threads and add 3/8" hex nut and tighten.

Make sure all bolts have been tightened.

